

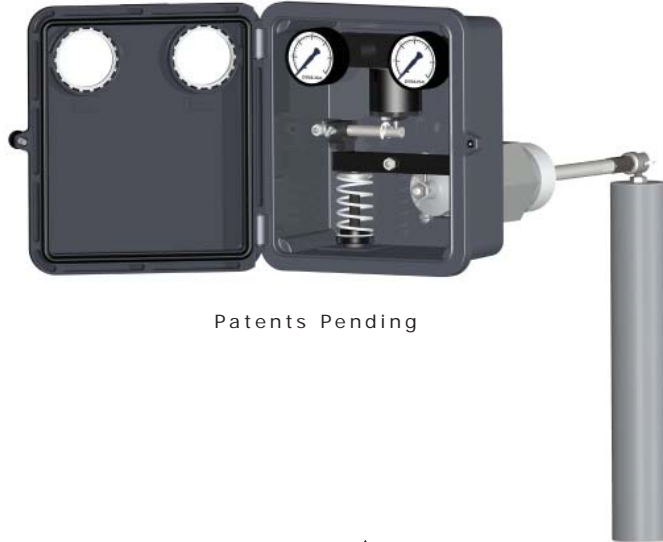

Model 5000 Level Controller



Patents Pending

Figure 1 Model 5000 Level Controller

The Dyna-Flo 5000 series level controllers are implemented for use in many demanding applications, including oil and gas production and chemical process industries. Typical applications would be on gas scrubbers and separators, where liquid level control is required as well as natural gas compressors and process control applications.

The 5000 level controller (Figure 1) utilizes an innovative relay manifold design providing easy maintenance and greater safety. The controller provides a pneumatic signal output for use with a control valve. The design allows for operational consistency through high and low pressure applications. Incorporated into the 5000 controllers design is unique access to the seal around the displacer arm, making maintenance effortless.

The Dyna-Flo 5000 series level controllers are manufactured to a superior level of quality and design to ensure impeccable performance and customer satisfaction.

Features

Multiple Configurations

The 5000 series level controller can be configured with a snap-acting or throttling pilot. This controller is also easily changed to a reverse or direct acting unit.

Adjustment of the displacer to vertical or horizontal position with no additional parts can be performed in the field.

Familiar Adjustment

Operators will find the set up similar to level controllers they have used before.

Field Reversible

The output of the 5000 controller can be field adjusted to be reverse or direct acting without additional parts. Also, this controller features adjustable gain sensitivity.

Environmentally Friendly

Impact on the environment for this controller is reduced greatly through low-bleed relays. Low-bleed relays help to reduce the amount of operating medium needed.

NACE Service

Standard construction materials are available for applications handling sour fluids and gases. These construction materials comply with the recommendations of (NACE) National Association of Corrosion Engineers MR0175.

ASME Pressure Rating

The vessel connection components are designed and rated for ASME B16.34 Class 1500 service.

Vented Case

Natural gas is permitted as an operating medium because of the cases ability to vent away exhaust.

Easy Maintenance

This model supports efficient access to all internal components for easy inspections and maintenance. Seals can be replaced without disrupting the vessel connection.



Model 5000 Level Controller

Specifications

Configurations

Controllers

Throttling
Snap-acting

Sensors

Pivotal movement of displacer arm is transmitted to the controller by a displacer-style liquid level sensor mounted to the side of tank.

Standard Displacer Size

1-7/8" x 12 inches, 33 inches³
(48 x 305 mm, 541 cm³)

Minimum Specific Gravity

Snap-Acting Controller

Minimum specific gravity (specific gravity differential for interface applications) 0.1

Throttling Controller

Minimum specific gravity (specific gravity differential for interface applications) 0.1

End Connection	Maximum Pressure Rating at 38°C (100°F)
MNPT	3750 Psig (41,400 kPag)
150 RF	285 Psig (1965 kPag)
300 RF	740 Psig (5100 kPag)
600 RF	1480 Psig (10,200 kPag)
600 RTJ	1480 Psig (10,200 kPag)
900 RF	2220 Psig (15,200 kPag)
900 RTJ	2220 Psig (15,200 kPag)
1500 RF	3750 Psig (25,900 kPag)
1500 RTJ	3750 Psig (25,900 kPag)

Pilot

Pneumatic (standard)

Snap (on/off) 0-20 / 0-30 psig output
Throttle (modulating) 3-15 / 6-30 psig output

Electric (optional)

SPDT - Explosion Proof
DPDT - Explosion Proof

Supply Pressure Requirements

Snap-Acting Controller

3-15 or 0-20 psig output: 20-30 psig min.
6-30 or 0-30 psig output: 35-40 psig min.

NOTE

Do Not Use Supply Pressure Below 20 psig (140 kPag)

Maximum Sensor Operating Pressure

Conforming with Class 1500 pressure temperature ratings per ASME B16.34 up to maximum pressure of 3750 psig (25850 kPag)

Maximum Displacer Operating Pressure

3750 psig (25800 kPag)

Standard Pressure Gauge Indications (Supply and Output)

Triple scale gauges in 0 to 60 psig / 0 to 0.4 MPa / 0 to 400 kPag

Controller Connections

Output

1/4 inch NPT female located on back of case

Supply

1/4 inch NPT female located on the back of case

Case Vent

1/4 inch NPT located on bottom of case, vent screen apparatus included

Vessel to Sensor Connection

1-1/2", 2", 3", and 4" threaded (NPT) or flanged

Sensor Temperature Limits

O-Rings

-40 to 204°C (-40 to 400°F)

Displacer

-29 to 79°C (-20 to 175°F)

Operative Ambient Temperature Limits

For Controller: -29 to 71°C (-20 to 160°F)



Model 5000 Level Controller

Figure 2 5000 Level Controller Dimensions

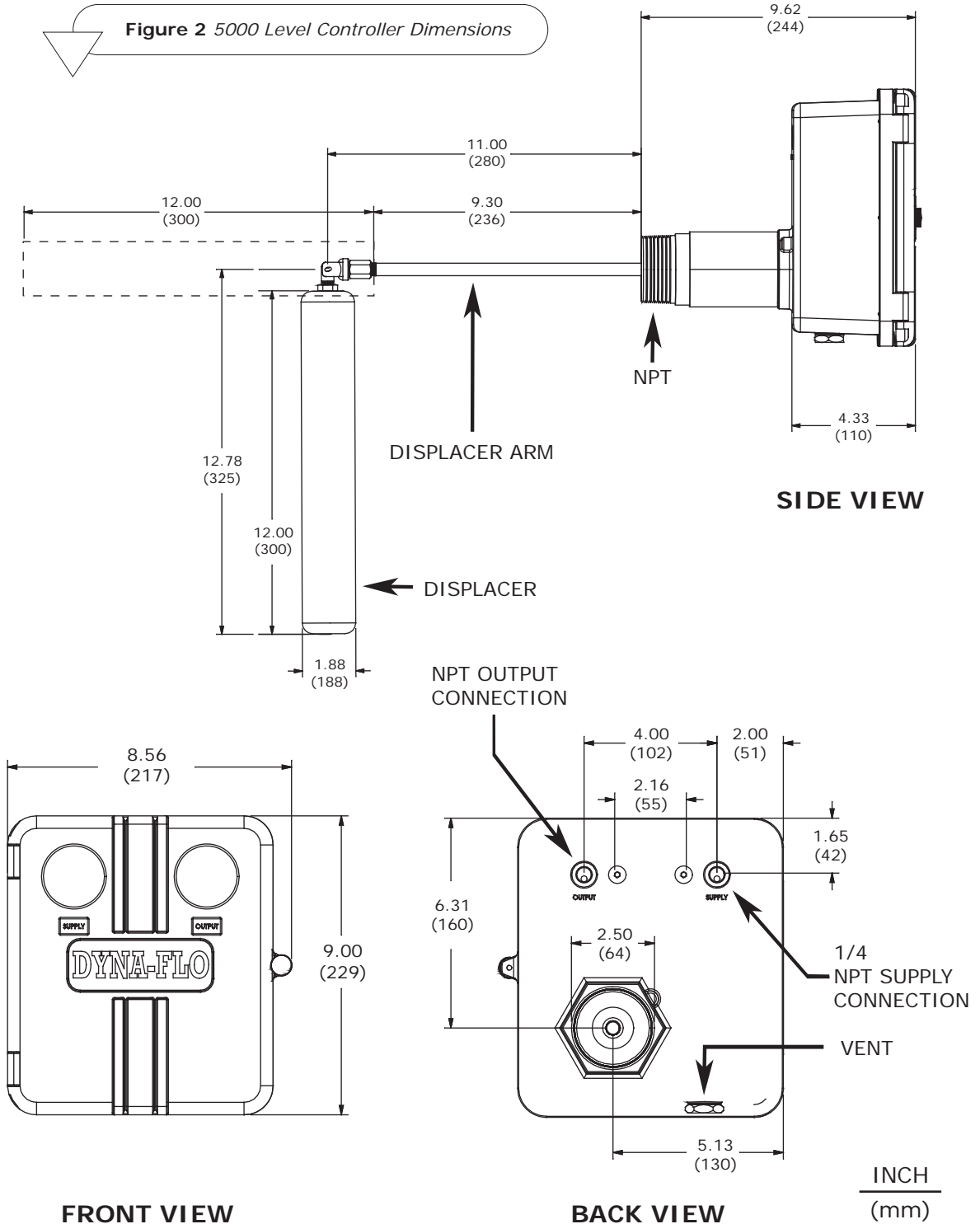



Model 5000 Level Controller

Operation Principles

The Series 5000 liquid level controller utilizes the "Force Balance System" (Fig. 5). Force is applied to the Fulcrum Bar distributed from the displacer-style level sensor using a series of levers and rods. The application of force to the Fulcrum Bar is a direct result of the weight of the displacement type sensor. Forces acting on the Fulcrum Bar are balanced using a compressed spring on one side of the bar. As fluid levels in the tank increase the buoyant force acting on the displacer decreases its relative weight. Force applied to the Fulcrum Bar is, in turn, decreased resulting in the rotation of the Fulcrum Bar until the forces are balanced again. A fulcrum mounted to the Flapper Shaft relays rotation of the Fulcrum Bar to the Pilot. Desired controller output can be regulated by adjusting the position of the fulcrum on the Fulcrum Bar. By using a Throttling pilot, a pneumatic modulating signal is achieved. A Snap-Acting pilot will result in a pneumatic on/off signal. Electrical SPDT or DPDT output is attained by utilizing an electrical limit switch.

Controller Action

The installation of the Flapper Shaft determines controller action (Fig. 6). When controller output is effected in the same as liquid level, the control is considered "Direct-Acting". When the vessels liquid level increases, the output signal will increase and vice versa. For example, when the Flapper Shaft is positioned on the left hand mount, the result is "Direct-Acting" control. "Reverse-Acting" control is achieved when change in liquid level results in a reverse effect to the pilot. As liquid level increases, controller output will decrease. When the Flapper Shaft is positioned on the right hand mount, the controller is considered "Reverse-Acting".

Proportional Band

Proportional Band is the ratio of used displacer length versus the total length of the displacer. Proportional Band is used in order to achieve a desired output signal (Fig. 3).

For example if a 12" long vertical displacer is used with six inches of fluid level change in order to develop a required output signal (ex: 3-15 psig), then the controllers Proportional Band is considered to be 50%.

Adjusting the Fulcrum (on the Flapper Shaft) towards the Pivot Pin away from the Snap-Ring will increase Proportional Band (decreasing sensitivity)(Fig. 3). By adjusting the Fulcrum away from the Pivot Pin towards the Snap-Ring will decrease Proportional Band (increasing sensitivity). Adjusting the Fulcrum as described above (over any portion of the displacer) can achieve a desired output signal such as 3-15 psig or 6-30 psig.

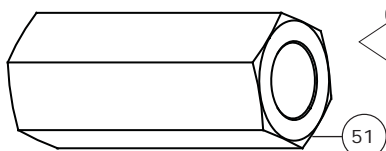
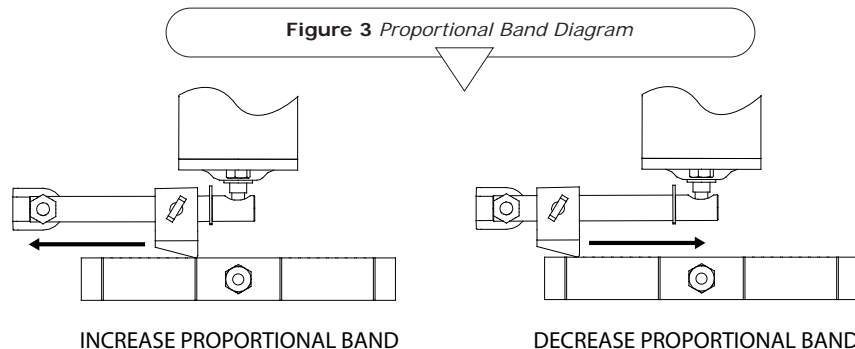

Figure 4 Retainer Removal Tool

The Retainer Removal Tool (Key 51) is made for use with a 1/2" socket and is essential for extracting the Retainer (Key 45) from the Body (Key 1). The Removal Tool is designed to slide over the Displacer Arm (Key 10) after removal of the Trunnion Head (Key 11) to remove the Retainer in order to service the O-Rings (Key 38, 39).



Model 5000 Level Controller

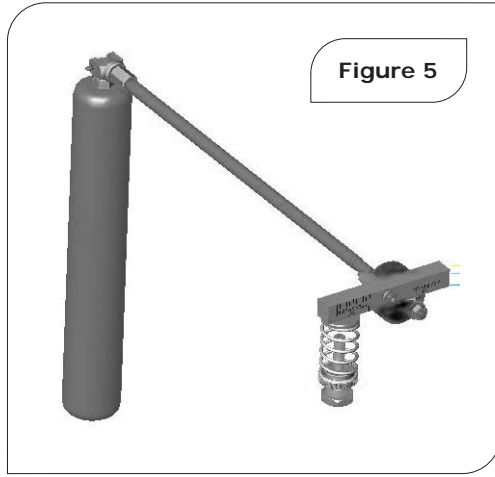

Figure 5

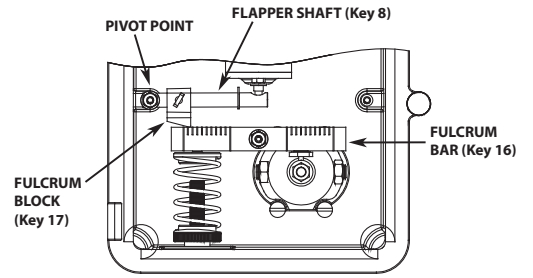
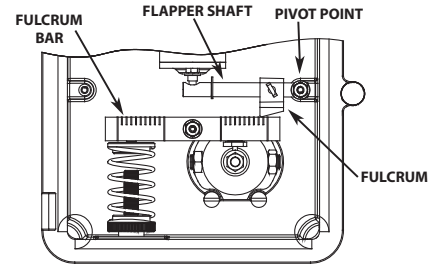

Figure 6

DIRECT ACTING



REVERSE ACTING

Figure 7 Model 5000 General Details

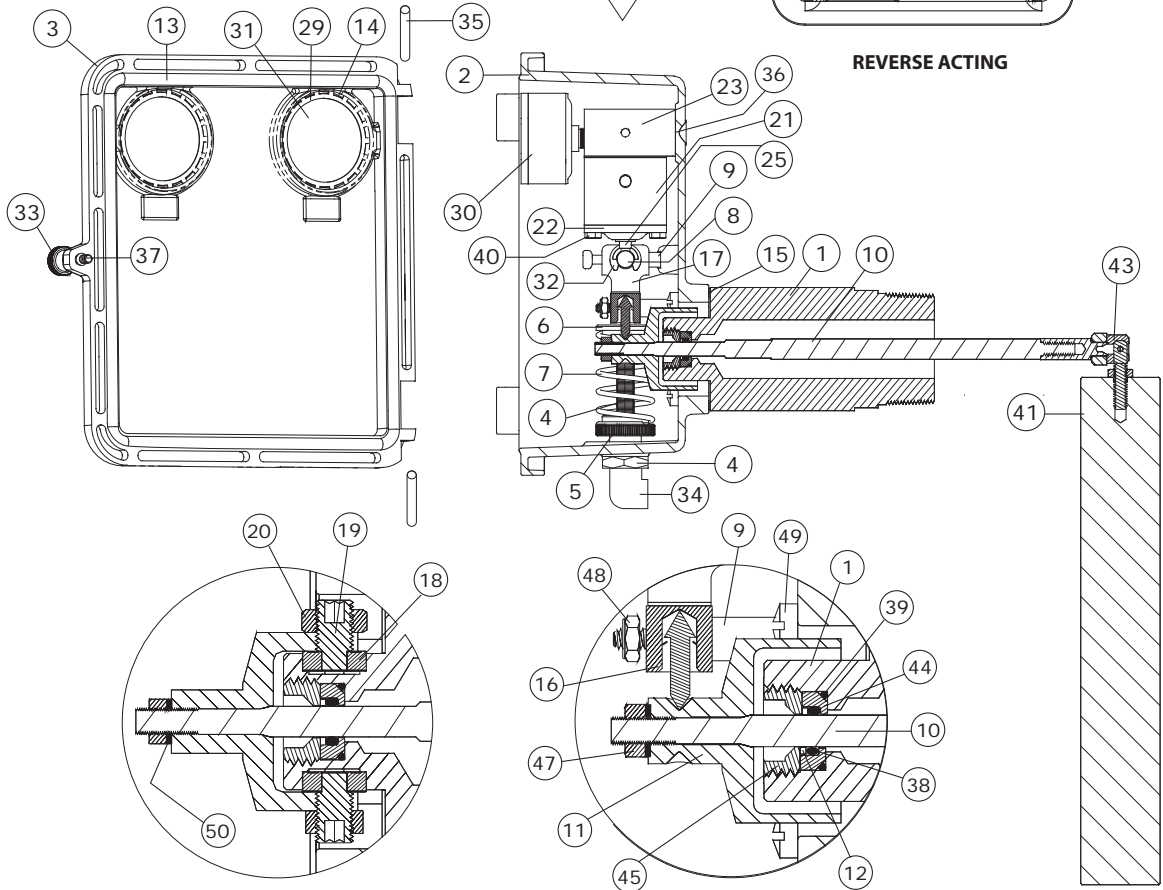



Model 5000 Level Controller

Table 1

Model DF5000 Construction Materials

Keys	Parts	Standard Materials
1	Body, 2" NPT	A350 LF2
2, 3	Case / Cover	Aluminum
4	Adjusting Thread	Aluminum
5, 6	Spring Adjuster / Spring Seat	Aluminum
7	Spring	302 SST Wire
8	Flapper Shaft	303 SST
9	Mounting Pins	303 SST
10	Displacer Arm	316 SST
11	Trunnion Head	Aluminum
12	Backup Ring	PTFE
13, 14, 15	Gaskets, Cover / Gauge Glass / Body	Neoprene
16	Fulcrum Bar Assembly	303 SST / 18-8 SST / Aluminum
17	Fulcrum Block Assembly	18-8 SST / Nylon
18	Trunnion Bearings	440 SST
19	Bearing Screw	303 SST
20	Jam Nut, Bearing Screw	18-8 SST
21, 22, 23	Pilot Body / Cap / Manifold	Aluminum
24	Pilot Filter	Cellulose
25, 26	Pilot Thrust Pin / Throttle Thrust Pin	316 SST
27	Throttle Pin Assembly	316 SST/Neoprene/Nylon/Teflon
28	Throttle Spring	302 SST Wire
29	Glass Retainer	SST
30	Gauge	Brass
31	Gauge Glass	Lexan
32	Retaining Ring	Zinc Plated
33	Case Cover Screw	Plastic / SST
34	Elbow Vent	Plastic / Metal Screen
35	Spring Pin, Door	Zinc Plated
36, 37	O-Ring, Manifold / Door Screw Retainer	Nitrile
38, 39	O-Ring, Displacer Arm / O-Ring, Seal Carrier	Nitrile / Viton
40	Socket Cap, Manifold	SST
41	Displacer	PVC / SST / Acrylic
42	Ball Bearing	302 SST
43	Swivel Assembly	316 SST / 18-8 SST
44, 45	Seal Carrier / Retainer	316 SST
46	Mounting Screws, Case	18-8 SST
47	Nut, Displacer Arm	Zinc Plated
48	Nut	18-8 SST
49	Machine Screw	18-8 SST
50	Lockwasher	Zinc Plated
51	Retainer Removal Tool	4140 HTSR / Zinc Plated

Activation

Adjust the Spring compression by setting the Spring Adjuster to position the Displacer Arm. Test the Fulcrum Bar by hand to check that the Displacer Arm is not resting against the vessel connection.

Figure 8 Level Adjustment Diagram

To Increase Level:

Turn the Spring Adjuster clockwise to decrease spring compression.

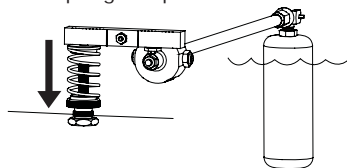

To Decrease Level:

Turn the Spring Adjuster counter-clockwise to increase spring compression.

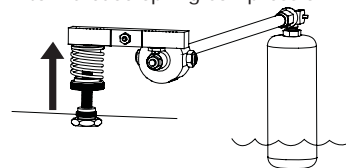



Model 5000 Level Controller

Snap Pilot Operation

Two valves compose the Snap pilot (Fig. 9); one valve to exhaust system pressure and one to admit supply pressure. Flow of supply pressure gas into the pilot is controlled by Ball 'A' (Key 39), force exerted by supply pressure holds the pilot closed by forcing Ball 'A' on the pilot seat.

When sufficient force is transferred from the Flapper Shaft (Key 8) to the Thrust Pin 'B' (Key 25), Ball 'A' will snap off the seat, releasing supply gas through the output port. As soon as Ball 'A' snaps open, the seating end of Thrust Pin 'B' seats and simultaneously closes the exhaust port. Because the Thrust Pin has a smaller seating area than Ball 'A', the Thrust Pin can remain seated against the force of supply pressure until force from the Flapper Bar subsides.

The "snap" action occurs as a result of differences in seating area between the Ball and Thrust Pin. Once force from the Flapper Shaft subsides, supply pressure will unseat the Thrust Pin 'B' and simultaneously seat Ball 'A'. As Thrust Pin 'A' is unseated it opens the exhaust port, venting supply gas.

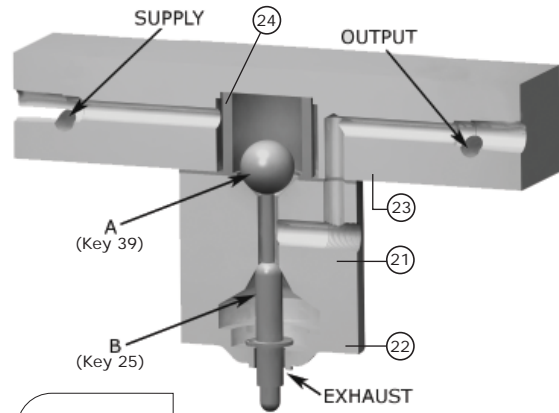

Figure 9

Throttle Pilot Operation

A Throttle pilot (Fig. 10) is similar to the Snap pilot, both consist of two inner valves. The difference between Snap and Throttle being the use of a Resilient Diaphragm 'C'. A Force Balanced pilot is created utilizing the Resilient Diaphragm in conjunction with valves 'A' and 'B'. Force Balance occurs as a result of supply pressure acting on the Resilient Diaphragm equalizing force applied to it and force exerted by the Flapper Shaft.

In a Throttling pilot the force applied by the Flapper Shaft to the lower seat becomes relational to the force of output pressure. Increasing the amount of force applied to the Flapper Shaft will proportionally increase the amount of output pressure.

As force applied to the Thrust Pin changes, the pilot compensates by unseating valve 'A' to increase output pressure or by exhausting supply output at valve 'B', resulting in a new balance point. While the pilot is in balance, supply gas will not flow.

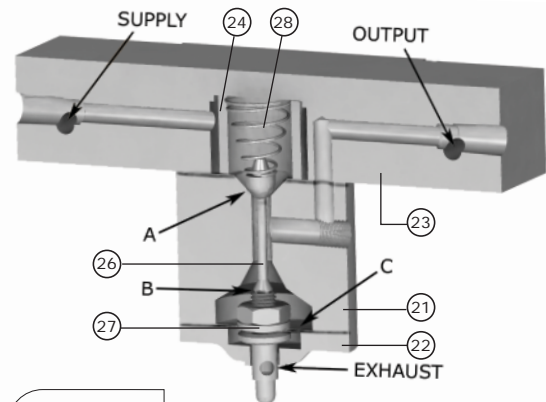

Figure 10

Our Commitment of Quality

Dyna-Flo is committed to continuous improvement. All efforts have been taken to maximize the accuracy of this information. Without notification, product specifications and designs may be modified at any time. The issue of this document is for information only, and does not imply suitability, a warranty, or guarantee for a specific service.



Model 5000 Level Controller

Ordering Guide

Dyna-Flo DF5000 Liquid Level Controller | Model Numbering System

Sample Part Number

5000—20MS—0S—B3B—VDP

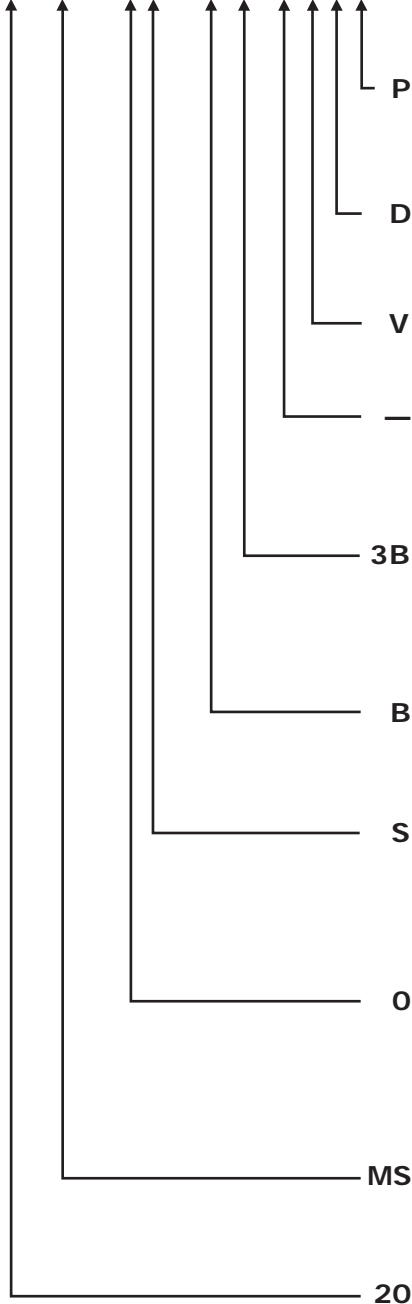

Code	Description
Displacer Material	
P	PVC
A	Acrylic
S	Stainless Steel
Displacer Size	
D	Standard (12")
B	6"
E	6" + 12"
X	Special
C	9"
Displacer Type	
V	Vertical
H	Horizontal
Displacer Arm	
-	Standard (17")
E	20"
C	11"
F	24"
D	14"
Gauge Type	
3B	0-30 Psi, Brass Internals
6B	0-60 Psi, Brass Internals
3S	0-30 Psi, 316 SST Internals
6S	0-60 Psi, 316 SST Internals
Seal Material / Backup Ring	
B	HSN (Highly Saturated Nitrile)(NACE) / CPTFE
V	Viton / CPTFE
X	Special
Pilot	
S	Snap (Pneumatic On/Off)
T	Throttle (Pneumatic Modulating)
Pressure Rating	
0	MNPT (3750 Psig)
1	ASME 150 (285 Psig)
3	ASME 300 (740 Psig)
6	ASME 600 (1480 Psig)
9	ASME 900 (2220 Psig)
5	ASME 1500 (3750 Psig)
End Connection Type	
MS	Screwed MNPT
RF	Raised Face Flange
RJ	Ring Type Joint Flange
SP	Special
End Connection Size	
15	1.5"
20	2"
30	3"
40	4"