

CYBOX AP 3-W

RAILWAY ACCESS POINT WITH WI-FI 5 WAVE 2 DUAL RADIO

ELTEC

systems

WESTERMO

MADE
IN
GERMANY



KEY FEATURES

- IEEE802.11ac compliant with 4x4 MU-MIMO Wave 2
- Up to two Wave 2 interfaces for dual band mode
- Backwards compatible with 802.11 b/g/n/ac
- Dual 1 Gigabit Ethernet on M12 X-coded connectors
- Optional high-speed Ethernet 10 GBaseT optical
- Optional bypass relays
- Power over Ethernet (PoE+) according to IEEE 802.3at
- Ultra-wide-range power supply 24 to 110 VDC
- Built-in cyber security
- Maintenance-free design
- -40 °C to +70 °C operating temperature
- EN 50155 compliant

TYPICAL APPLICATIONS

- Passenger Wi-Fi
- Passenger Entertainment
- Passenger Information
- Ticketing System
- Fleet Management
- Video Surveillance

HIGH-END WIRELESS COMMUNICATION

The CyBox AP 3-W is a member of the CyBox family – robust access points for railway applications. It is particularly designed to meet the requirements of rolling stock applications. It offers stable, secure, and high bandwidth connections between the local Ethernet and wireless clients. With the assistance of the access point, multiple mobile Wi-Fi-compatible devices in a passenger train or subway have the possibility to communicate with the Internet or access local data, such as timetable information and multimedia data.

BACKBONE CONNECTIVITY

On the fixed network side, the access point features two 1 Gigabit Ethernet ports and higher bandwidth options to create a faster backbone. The fiber optic option mainly addresses new infrastructures. The bypass relay option ensures a high-speed connection even if the router is powered down.

MULTIPLE POWER OPTIONS

The CyBox AP 3-W provides flexible powering options by either an internal power supply or Power-over-Ethernet (PoE+). The PoE daisy chaining offers wireless connectivity with two access points using just one cable – a noticeable cost saving factor especially in retrofit programs.

USER-INTERFACE AND SECURITY FEATURES

The CyBox AP 3-W firmware provides a convenient management interface via a web service. Besides global setup parameters the open source software OpenWrt allows the configuration of the radio interfaces, including provider information and the login dialog, as well as the setup of the stateful firewall. The access point and router configurations as well as the management firmware can be updated remotely. Furthermore, the built-in fully configurable stateful firewall and multi-VPN support with hardware-accelerated encryption ensures communication security.

BLOCK DIAGRAM

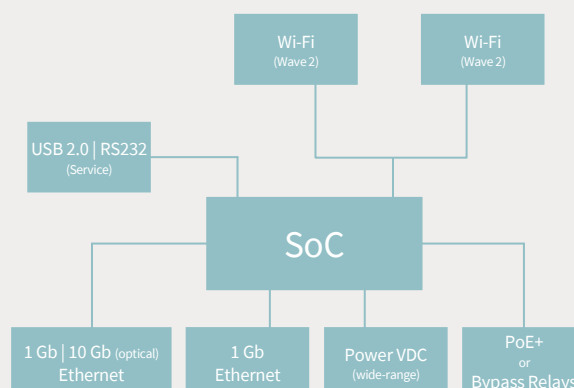

CYBOX AP 3-W

RAILWAY ACCESS POINT WITH WI-FI 5 WAVE 2 DUAL RADIO

ELTEC

systems

WESTERMO

TECHNICAL DATA

PHYSICAL INTERFACES	
System Architecture	Dual-Core CPU T1023, 1200 MHz 1 GB RAM, 128 MB Flash
Software	Linux OS OpenWrt
Antenna	QLS connectors
LAN	1 GBaseT M12 X-coded or 10 GBaseT SFP optical
USB/Serial Port	M12 8-pin female A-coded, USB 2.0, RS232
Power Input	M12 4-pin male A-coded
Reset Switch	available on front panel

ELECTRICAL SPECIFICATIONS	
Power Supply	24 to 110 VDC, wide-range power supply (compliant to EN 50155)
Power over Ethernet	PoE+, Class-4 powered device, IEEE 802.3at
Interruptions of Voltage Supply	EN 50155, Class S2
Power Consumption	20 W typ., 25 W max.

ENVIRONMENTAL CONDITIONS	
Ambient Temperature	depending on temperature class of Wi-Fi module Class OT4, -40.. +70 °C (85 °C) operating or Class OT3, -25.. +70 °C (85 °C) operating -40.. +85 °C storage
Humidity	max. 95 % non-condensing operating and storage
Altitude	Class AX, up to +2000 m
PCB Protection	conformal coating

RELIABILITY	
MTBF	approx. ~350.000 h

MECHANICAL SPECIFICATIONS	
Dimensions	105 (130) mm x 70 mm x 204 mm (w h d) (incl. mounting points)
Weight	up to 1850 g
Housing	IP40, aluminum, wall-mount, conductive cooling

OPTIONS

Modules	various combinations of Wi-Fi modules
Antenna Connectors	QLS to SMA adapter

Order numbers on standard configuration sheet and www.eltec.com

MODULES

WI-FI INTERFACE IEEE 802.11 a/b/g/n/ac/ac Wave 2	
Transfer Rates	up to 1733 Mbps
Frequency Range	2.412 GHz to 2.484 GHz, or 5.180 GHz to 5.825 GHz, selectable band
RF	4x RF antennas, 4x4 MU-MIMO technology
Encryption	AES, TKIP, WPA, WPA2, WPA3
Operational Feature	up to 256 clients per radio
Security	stateful firewall with multi-level client isolation

STANDARDS AND SPECIFICATIONS

Directive (EU) 2016/797	EN 50155 (IEC 60571)
	EN 45545-2 (HL 1 to HL 3)
	EN 61373 (Category 1, Class B)
RED – 2014/53/EU	EMC
	radio spectrum
	health & safety
FCC	Title 47 CFR Part 15B (on request)

EVALUATION KIT

ORDER NO.	DESCRIPTION
EVAPW-3030V0	based on model CYAPW-3030V0
	2x Wi-Fi 802.11ac Wave 2, 2x 1 Gb ETH (M12X), PoE+

All kits incl. antennas, adapters, cables and power supply in ruggadized suitcase